

Disc sander TG 125/E



With associated horizontal C-clamp (with table), but can also be fixed vertically quickly and safely (to sharpen tools).



Suction channel with adapter to connect a vacuum cleaner.



Sanding disc (125mm). Self-adhesive sanding discs can be easily removed after use.

Table tilting through 50° downwards and 10° upwards. With angle stop. With C-clamp for horizontal and vertical fixing (see figure above).

For all wood types, steel, non-ferrous metals, precious metals, plastics (also Plexiglas and fibreglass).

Powerful drive and vibration-free running thanks to balanced DC motor. Housing of glass-fibre reinforced POLYAMIDE. Aluminium table tilting through 50° downwards, 10° upwards. With angle stop. Sanding disc with affixed silicone film. This surface ensures easy removal of self-adhesive sandpaper. Two additional square silicone films allow for easy storage after use and thus reuse as necessary. Machine can be secured horizontally (with table) on the workbench, but also quickly and safely in vertical position.

Suction channel with union to connect a vacuum cleaner for dust-free working. Each with 2 sanding discs grit 80, grit 150 and grit 240.

Technical data:

220 – 240V. 140W. 50/60Hz. Adjustable grinding speed of approx. 250 – 800m/min (corresponds to 1,150 – 3,600rpm). Sanding disc Ø 125mm. Table 98 x 140mm. Sanding height 62.5mm. Size 300 x 140 x 160mm. Weight approx. 3kg.

NO 27 060

Self-adhesive white corundum sanding discs for TG 125/E

Industrial quality. For sanding soft and hard woods, chip-boards, fibre boards, non-ferrous metals, steel, plastics, cork, rubber and minerals. Ø 125mm. One quadratic silicone film for storage and reuse of used sanding discs is included.

NO 28 160	80 grit	5 pieces
NO 28 162	150 grit	5 pieces
NO 28 164	240 grit	5 pieces

Note:

For dust-free work we recommend our Compact Workshop vacuum cleaner CW-matic (see page 42) with integrated automatic switching unit: Vacuum runs during grinding, switching your tool off stops the vacuuming with a run-on time of 5 seconds.

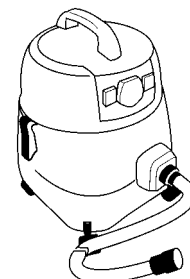

Disc sander TSG 250/E

Sands long edges, end sections, radii, mitres, and, by turning the workpiece over - accurate flat surfaces at right angles.

Used on soft and hard woods, non-ferrous metals, steel, plastics (perspex and PC cards), cork and rubber. A simple chart indicates the recommended speeds on different materials.

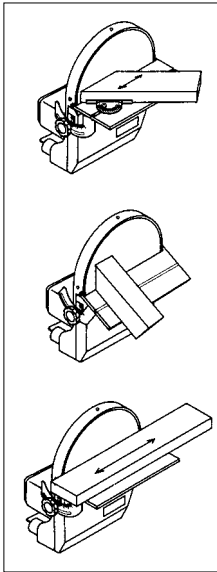

Sturdy construction:

Main body of ribbed die-cast aluminium (no steel tube or sheet metal construction). Turned flat grinding disc, provided with silicone film: This ensures that affixed sanding discs can be removed effortlessly after use. Two additional square silicone films for storage and reuse of used sanding discs are included. With dust collection adapter for connection to a vacuum cleaner for dust-free working. Complete with mitre gauge and 2 each sanding discs in grain 80 and 240.

Technical data:

220 – 240V with drive via opti-belt toothed belt (reduction ratio 7.3:1). Electronic speed control approx. 250 – 750m/min. Disc diameter 250mm. Maximum sanding height 135mm, table 275 x 105mm (tilts 15° in, 45° out). Overall size without table 330 x 280 x 230mm.

NO 28 060

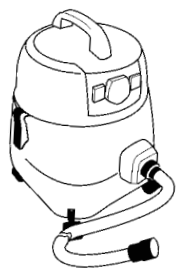

With suction connection and adapter for dust-free, clean sanding. We recommend our Compact Workshop vacuum cleaner CW-matic (see page 42).

Self-adhesive corundum sanding discs for TSG 250/E

Industrial quality. For sanding soft and hard woods, chipboards, fibre boards, non-ferrous metals, steel, plastic, cork, rubber and minerals. Ø 250mm. Includes silicone film for storing used sanding discs.

NO 28 970	80 grit	5 discs
NO 28 972	150 grit	5 discs
NO 28 974	240 grit	5 discs



Self-adhesive silicone carbide sanding discs for TSG 250/E

For sanding non-ferrous metals, steel, glass, PC cards, plastics and ceramics. Ø 250mm. Includes silicone film for storing used sanding discs.

NO 28 976	320 grit	5 discs
------------------	----------	---------

Self-adhesive silicone film for easy sanding disc replacement (Ø 250mm)

For retrofitting older disc sanders TG 250/E (production before 2007 with serial no. up to 14190). Is attached to the sanding disc. Ensures that affixed sanding discs can be removed effortlessly after use. With 4 square silicone films for storage and reuse of used sanding discs.

NO 28 968	set
------------------	-----

With setting screw for fine adjustment of the longitudinal stop by 1/10 through 45°. For precise, straight cuts without refinishing!

Table saw FET



Extendable table extension with integrated auxiliary stop.

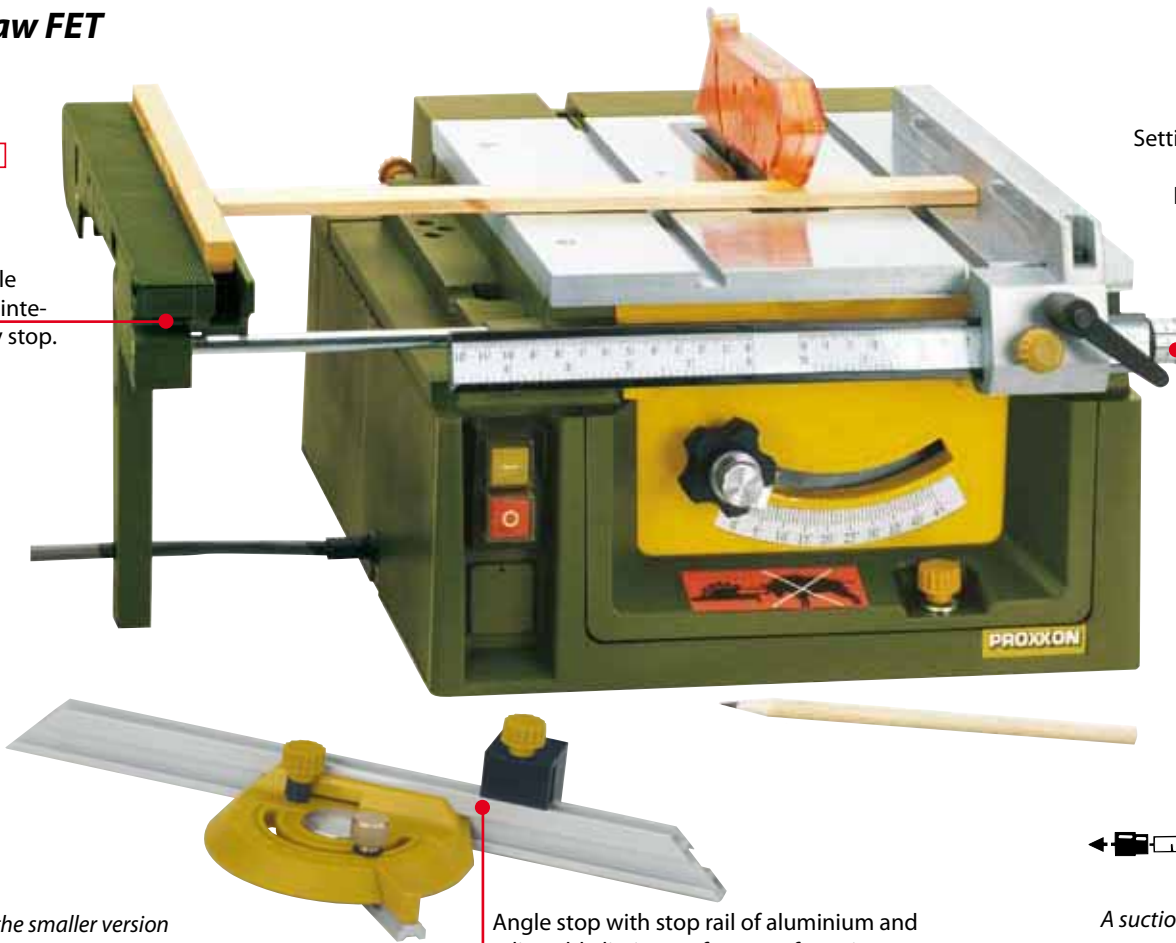

Setting screw for fine adjustment of longitudinal stop by 1/10mm.

Angle stop with stop rail of aluminium and adjustable limit stop for manufacturing parts of equal length and the same angle.

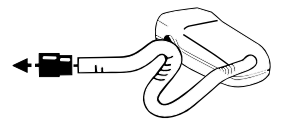

A suction connection with vacuum cleaner adapter permits clean working.

Note:
You will find the smaller version of the FET (circular saw KS 230) on page 32.



Practical holder for the suction connection included:

For retaining the vacuum cleaner hose. With 32mm clamp to accept the suction connection, and 20mm collar for insertion into the universal holder UHZ as well as a strap for clamping in any vice.

Compact workshop vacuum cleaner CW-matic.
For connecting electric tools of 25 - 2,000W.

The vacuum cleaner runs as long as the machine does work. Follow-up time of 5 seconds after switching off the power tool.

Smooth operation with high suction capacity. With large fluted filter made of polypropylene to be cleaned and washed manually. Additional fine dust paper filter (not essential for this function). Container is easily emptied by removing the appliance lid with the motor unit. Blowing function available by refitting the vacuum hose. Also suitable for vacuuming liquids. Complete with 3.5m vacuum hose, 2-part aluminium vacuum pipe (98cm), floor nozzle, brush nozzle, crevice nozzle and adapter for connection to standard adapter of all such equipped PROXXON machines. Includes 6 fine dust paper filters.

Technical Data:

220 – 240V. 1,100W. Connection for electric tools from 25 to 2,000W. Container 18l. With 5m connection cable.

NO 27 490



Fine dust paper filter for CW-matic

For additional filter function. Must be removed when vacuuming liquids.

NO 27 494 5 pieces

Fluted filter for CW-matic

Made of polypropylene. Can be cleaned dry or wet.

NO 27 492 1 piece



mm. Height adjustable tungsten-tipped saw blade tilting

For fine mechanics, model building, mould construction, toy manufacture, architects, model carpenters and fitters.

For cutting wood, non-ferrous metals, plastics, Plexiglas, glass fibre reinforced sheets, foam and many other materials. Stable construction because load bearing parts and plane-milled table are made of die-cast aluminium.

The micro-adjustable, precise and stable longitudinal stop provides decisive advantages: Corrections even smaller than 1/10 mm can be made after coarse adjustment using an adjusting screw. The height adjustable and 45° tiltable saw blade makes it possible to cut double mitres when used together with the angle stop.

Low-noise drive using DC special motor with Optibelt toothed belts. Ball-bearinged saw blade shaft. Tungsten tipped saw blade 80 x 1.6 x 10mm (24 T). Additional work piece pusher and non-slotted ABS sawing gap cover for tight tolerances between saw blade and table.

Technical data:

220 – 240V. 7,000rpm. Mitre infinitely adjustable up to 45°. Table size 300 x 300mm. Cutting depth 1 - 22mm. Saw blades between 50 - 85mm can be used (with 10mm centre hole). Weight approx. 6kg.

NO 27 070



Non-slotted sawing cap cover of ABS for tight tolerances between saw blade and table (is slotted from below by the FET saw blade). For cutting very small parts.



Table and drive can be lifted up and supported like an engine bonnet. For cleaning the device and easy saw blade replacement.



T-slot milling device

For table saws FET and FKS/E. Consisting of milling protection and tungsten tipped saw blade 50 x 2 x 10mm. For cutting slots in drawers, picture frames, etc. Milling depths max. 8mm. Easy to assemble.

NO 28 736



Super cut
Ø 85 x 0.5 x 10mm.
80 teeth. Use on hard and soft woods, plastics.

NO 28 731



Tungsten carbide tipped
Ø 80 x 1.5 x 10mm.
36 teeth. Use to cut balsa, plywood, hard and soft woods, POLYCARBONATE, plastic, aluminium and PC cards.

NO 28 732



Tungsten carbide tipped
Ø 80 x 1.5 x 10mm.
24 teeth.
Use on aluminium, hard wood, laminates, plastics.

NO 28 734



Diamond coated
Ø 85 x 0.7 x 10mm.
Layer 'D100'
Ceramics, porcelain, tiles, stone, PC cards

NO 28 735

Thickneser DH 40.

The smallest and finest in the world!

Load bearing components are all made of die-cast aluminium, with milled seats for bearings and spindles.

These characters are essential for vibration-free, smooth thickening of soft and hard woods. Triple-spindled table (of die-cast aluminium, flat-milled) which can be accurately adjusted to 1/10mm by handwheel (zero adjustable). Automatic even feed with anti-kickback device: The knurled, spring-mounted infeed roller transports even irregularly shaped work pieces. A rubber-coated outfeed roller prevents marking the newly planed surface. Precision planer block with two HSS planer blades.

Technical Data:

220 – 240V. 200W. 50/60Hz. Thickening up to 40mm thick and up to 80mm wide. Maximum depth of cut 0.8mm. Cutter speed 6,000rpm. Feed rate 4.8m/min. Table length 232mm. Weight approx. 8kg.

NO 27 040

Spare blades

For thickneser DH 40. Made of HSS. Length 82mm.

NO 27 042 1 pair





Cut off/mitre saw KGS 80

Note:

You will find the smaller version of the KGS 80, our mini cut-off saw KG 50 (weighs only 1.5kg instead of 6.0kg) on page 34. Optional saw blades for the KGS 80 are offered on page 43.

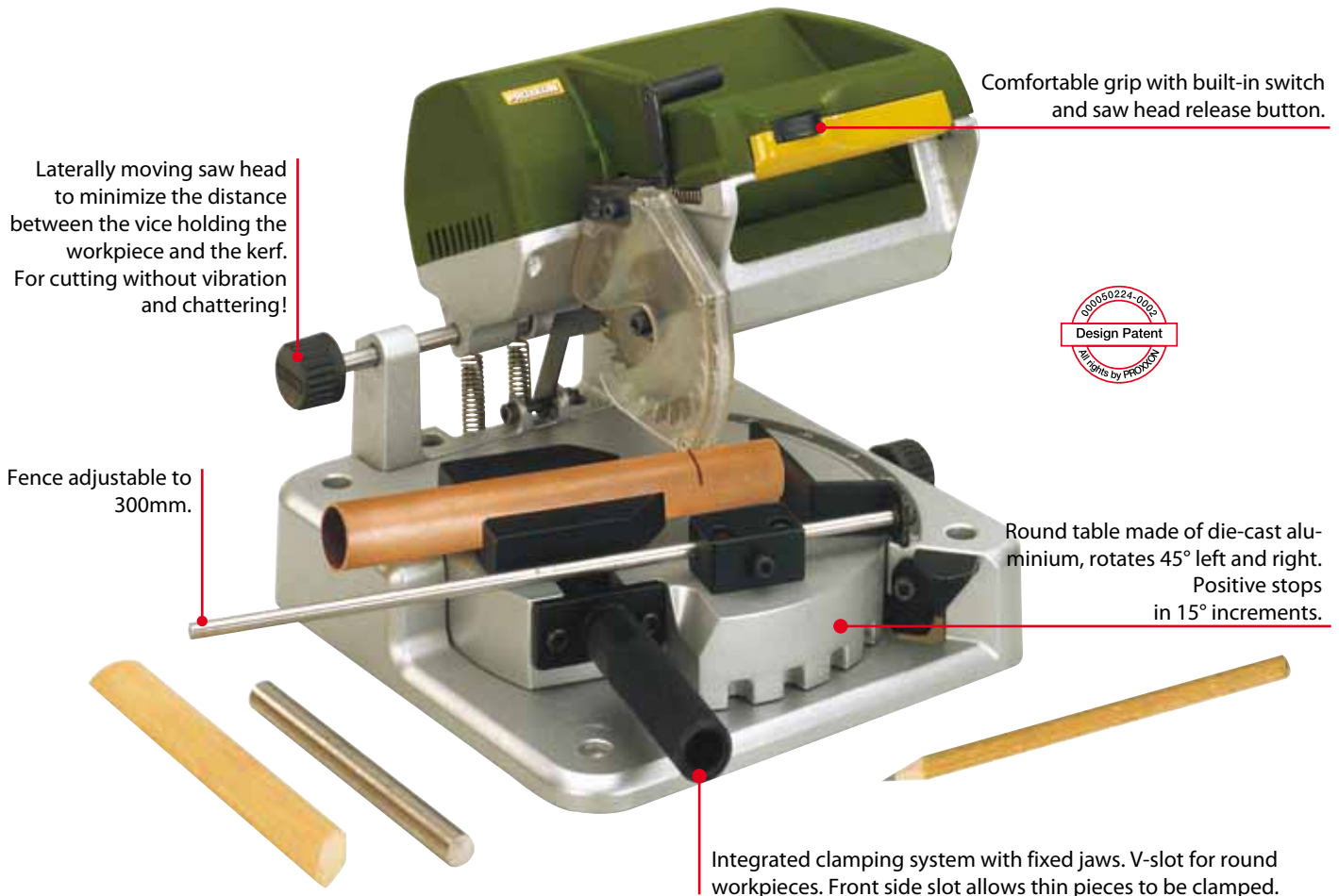

Ideal for mitre cuts: Adjustments are made to the round table (with clamped work piece) and not to the headstock!

The opposite angle for a second frame part of identical length occurs through simple shifting with the longitudinal stop and by rotating the table by 2 x 45°. Powerful, quiet DC-motor. Smooth toothed belt drive ensures power transmission. Tungsten-tipped saw blade for non-ferrous metal, wood and plastics (80 x 1.6 x 10mm, 24 TPI).

Other technical data:

220 – 240V. 200W. 50/60Hz. 6,000rpm. Base with round table of highly stable die-cast aluminium with CNC-milled fittings and slides. Table 230 x 230mm. Weight 6kg. See table for cutting capacity.

Cutting capacity at 90° (right angle cut)			Cutting capacity at 45° (mitre cut)		
Material size (in mm)	Max. material width (in mm)	Round material (in mm)	Material size (in mm)	Max. material width (in mm)	Round material (in mm)
10	65		5	36	
18	50		10	30	
21	40		15	25	
25	25	Ø max. 25	20	18	Ø max. 20

Cutting disc, with reinforcement.



Corundum-bound and shatter-proof. For cutting alloyed and non-alloyed steel, stainless steel and non-ferrous metals. Also suitable for wood and plastics.

NO 28 729 80 x 1.0 x 10mm

Tungsten tipped circular saw blade (36 T).



Extremely clean cut edges thanks to high tooth count when cutting balsa, plywood, soft wood and glass reinforced plastic boards. Also for cutting hard wood, POLYCARBONATE, plastics and aluminium.

NO 28 732 80 x 1.6 x 10mm

2-speed scroll saw DS 460



Extremely important for scroll saws: A handy adjusting knob enables sensitive clamping of the saw blades!

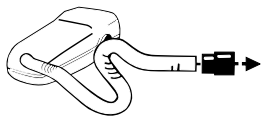

The DS 460 is equipped with a suction connection with vacuum cleaner adapter. For dust-free and clean working.

Note:

You will find the scroll saw DS 230/E, ideal for delicate projects, on page 33!

Sturdy construction: Vibration-reducing base housing of cast steel, neatly CNC-processed and powder-coated. For stability and working without vibrations.

Magnesium saw arms precisely mounted on bearings: Extremely light and firm with a slender-shaped cutting area for an unobstructed view of the work piece. Chip blowing device with adjustable nozzle. Additional suction connection to connect a vacuum cleaner.

Large saw table made of die-cast aluminium (400 x 250mm). For easier saw blade replacement, it can be unlocked and pushed back (see description at top right). Regular scroll saw blades are fastened by saw blade holders with high clamping force: This ensures true alignment in the saw arm! The machine has also been prepared for saw blades with pin ends that are used without blade holders. Extremely important for these types of scroll saws: A handy adjusting knob enables sensitive clamping of the saw blades!

Table angle adjustment possible from 5° to 50° (see bottom right).

Cutting performance in wood 60mm, in non-ferrous metals (depending on type) 10 - 15mm. Also easily cuts Plexiglas, glass fibre reinforced plastic, foam, rubber, leather or cork. Includes 5 each coarse and fine saw blades.

Technical Data:

220 – 240V. Powerful, brushless 2-speed motor (205W). Throat 460mm. Stroke alternatively 900 or 1,400rpm. Saw stroke 18mm. Table size 400 x 250mm. Maximum work piece passage 65mm (at 45° mitre 32mm). L 580mm, W 320mm, H 300mm. Weight 20kg.

NO 27 094

Blade holders for DS 460

(one pair is already included with the machine).

For clamping regular saw blades with high clamping force: for true alignment of the saw arm.

NO 27 096

2 pieces



be moved by 40% as compared to die-
g. Throat 460mm.

Table pushed back by 80mm.

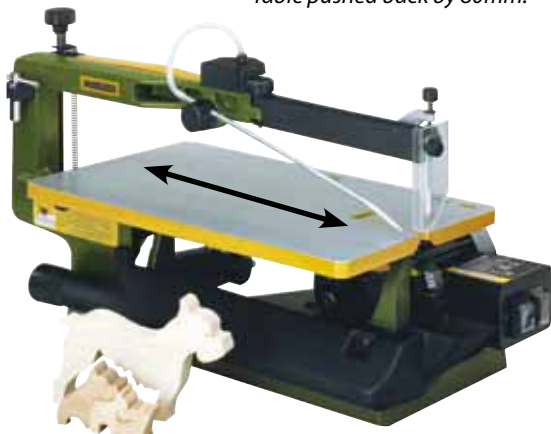

Innovative solution (patented): To enable easy saw blade replacement, the horizontally positioned table can be unlocked and pushed back by 80mm. For an unobstructed view of the bottom saw arm when fitting the saw blade holders or pin end blades.



Patented saw blade holders with high clamping force ensure true alignment of the saw blades. Recesses in the table surface serve as guide line in assembly to define position and distance of the saw blade holders.



Table angle adjustment possible from 5° to 50°. With large dimensioned serrations at 0°, 10°, 20°, 30° and 45°. Additional fine adjustment for precise mitre and angle cuts.

'Super-Cut' scroll saw blades without pins. 130mm.

For cutting soft and hard woods, plastics, Perspex, soft non-ferrous metals:

- Coarse-toothed blades (14 TPI):
NO 28 110 130 x 1.50 x 0.48mm 6 blades
- Normal toothed blades, (17 TPI):
NO 28 108 130 x 1.20 x 0.38mm 6 blades
- Fine-toothed blades (25 TPI):
NO 28 107 130 x 0.77 x 0.30mm 6 blades

For hard metals like iron or PERTINAX:

- Fine toothed blades (28 TPI):
NO 28 104 130 x 1.10 x 0.50mm 6 blades
- Extremely fine toothed blades (41 TPI):
NO 28 106 130 x 0.74 x 0.36mm 6 blades

Spiral blade. 125mm long with plain ends (without pins).

These blades cut all directions and obviate the turning of the workpiece (advantageous, especially with bigger workpieces). A 1.5mm hole is required. Ideal for plastic, hard and soft woods.

- NO 28 746** 125 x 1.2mm 6 blades

Standard scroll saw blades with pin ends. 127mm:

Coarse pin end blades (10 TPI): ideal for cutting soft and hard wood, plastics as well as soft and above all also thicker material.

- NO 28 740** 127 x 2.61 x 0.51mm 6 blades
- Fine pin end blades (18 TPI): ideal for cutting thin materials, soft and hard wood as well as plastics.
NO 28 742 127 x 1.86 x 0.24mm 6 blades
- Very fine pin end blades (25 TPI): ideal for cutting non-ferrous metals, PC cards, plastics, perspex and wood.
NO 28 744 127 x 1.76 x 0.25mm 6 blades

2-speed scroll saw DSH. The 10,000-fold proven standard model with 400mm throat.



Cutting performance 50mm in wood, 30mm in plastic, 10mm in non-ferrous metals.

For cutting Plexiglas, glass fibre reinforced plastic, foam, rubber, leather or cork. Slender saw arm of die-cast aluminium for unobstructed view from top. Air blower with adjustable air nozzle. Sturdy table of die-cast aluminium (360 x 180mm), can be tilted by 45° for mitre sawing. Base housing of cast steel for stability and working without vibrations. Includes 5 each coarse and fine saw blades.

Technical Data:

220 – 240V. Powerful, brushless 2-speed motor (205W). Stroke alternatively 900 or 1,400rpm. Stroke length 19mm. Throat 400mm. Maximum cutting depth 50mm, at 45° mitre 25mm. Weight approx. 20kg.

NO 28 092

Lathe PD 230/E

Usable on materials such as steel, brass, aluminium and plastic. Complete with automatic feed, thread cutting capability, headstock chuck, live centre and top slide for taper turning. Used to part, machine stock and cut tapers. The numerous optional accessories allow one to drill, mill and slot.

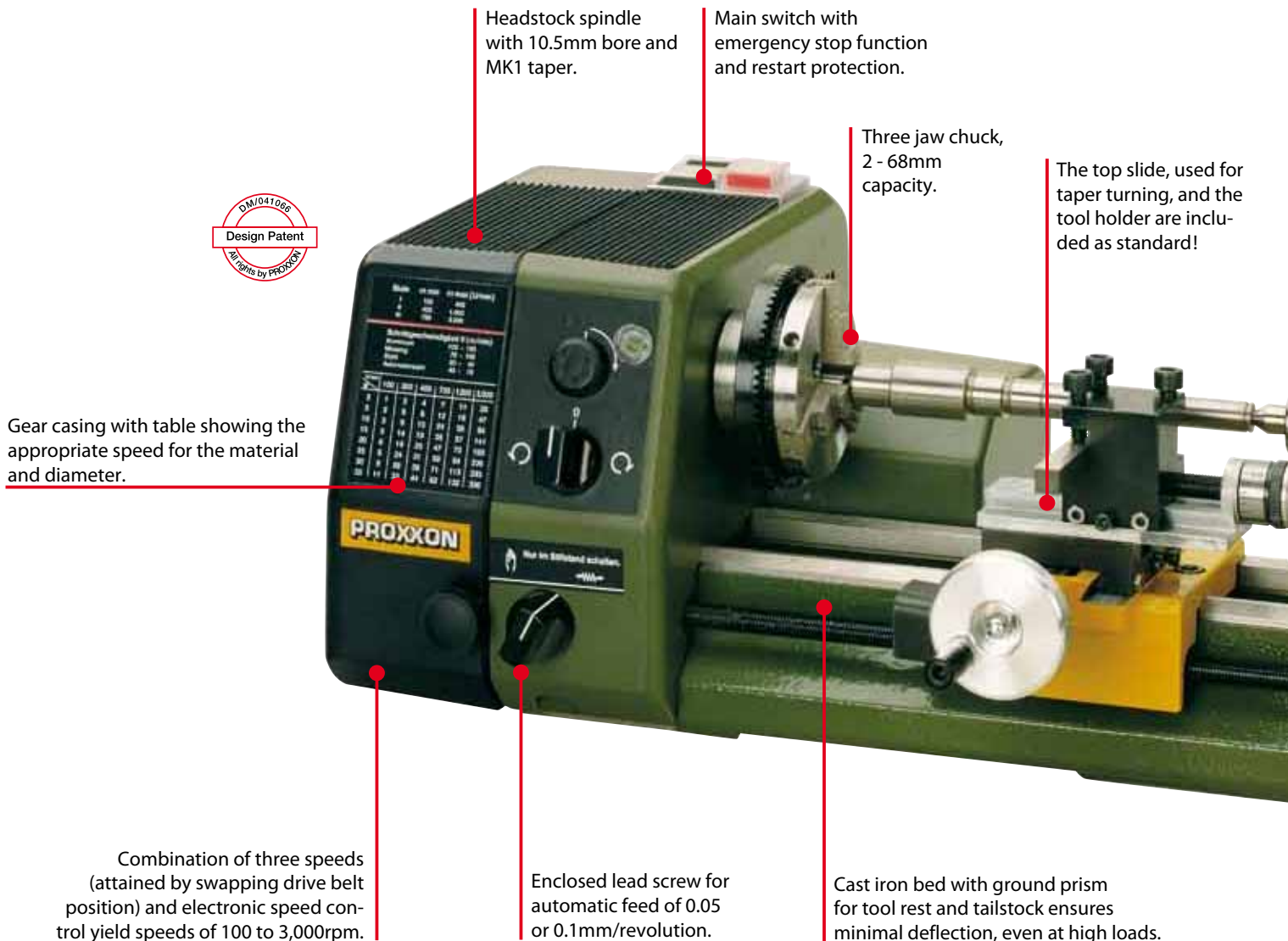

Technical data:

Centre distance of 230mm, swing 52mm. Height over cross slide 28mm. Cross slide travel 60mm and top slide 45mm. Steel tool holder accepts 8 x 8mm cutters. The MK1 (short) spindle has a 10.5mm bore. It runs in precision ball bearings, yielding an accuracy of 0.01mm without chuck. The thread cutting capability covers the most important pitches of 0.5 - 0.625 - 0.7 - 0.75 - 0.8 - 1.0 - 1.25 and 1.5mm. Spindle speeds are changed by means of a belt and offer 300 - 900 and 3,000rpm.

The electronic speed control further extends the speed range

down from 100rpm (which is important when cutting threads) to 3,000rpm. The automatic feed offers 0.05 or 0.1mm per revolution. The tailstock spindle has a MK1 (short) bore and 30mm travel. The quiet 220 - 240V motor is fitted with a forward/reverse switch. The three jaw chuck offers 2 - 35mm capacity (internal jaws) and 24 - 68mm (external jaws). The handwheels are fitted with zero adjustable scales. One revolution equals 1mm feed (20 divisions) and hence 0.05mm/division. Weight approx. 10kg and dimensions approx. 530 x 250 x 150mm.

NO 24 004

*Accessories for the lathe PD 230/E
(also compatible with its predecessor PD 210).*



Collet set covering 2.0 – 10mm for concentric accuracy better than 0.02mm.

For accurate use on round components. The collets are mounted in the place of the headstock chuck. Eight collets (one each 2.0 - 2.5 - 3.0 - 4.0 - 5.0 - 6.0 - 8.0 and 10mm) are included.

Supplied in a wooden box with sliding lid.
NO 24 042



Four jaw chuck. The 4 jaws are adjusted independently, thus clamping unsymmetrical pieces, ovals, squares and odd-shaped work pieces. Capacity of 80mm.

NO 24 030

MK 1 live centre included as standard.

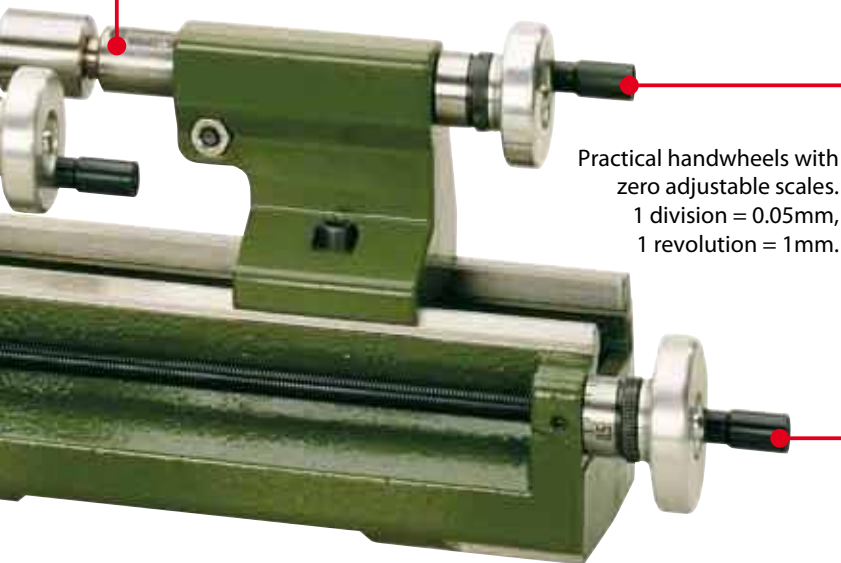

Practical handwheels with zero adjustable scales.
1 division = 0.05mm,
1 revolution = 1mm.



Centre turning attachment. Used for highest accuracy with high rotational precision.

One face plate, 2 fixed MK 1 (short) centres and 1 drive dog are included. Supplied in wooden box with sliding lid.

NO 24 070



Gear chuck

Capacity to 10mm, with key and MK1, for tailstock.

NO 24 020

As above, but with 10mm arbor. for mill/drill unit.

NO 24 110

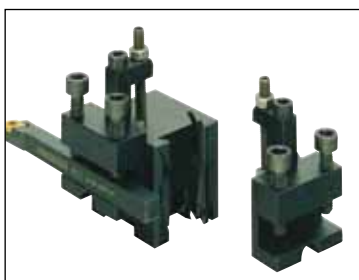

Quick change tool post for PD 230/E

Easy to use!

Enables quick tool changes and easy height adjustments. Including 2 tool holders for lathe tools up to 10 x 10mm.

NO 24 022

Additional quick change tool holder (separately)

Can be used with the above mentioned quick change tool post.

NO 24 024

piece

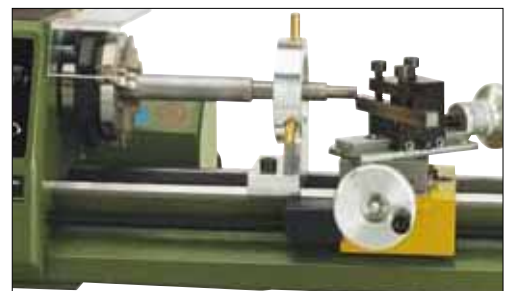

Fixed steady

Used when turning long, slender pieces, capacity up to 40mm (Ø). Also used when the tailstock cannot be utilised.

NO 24 080

Splash guard and chip collecting tray for PD 230/E



Made from 1.5mm thick sheet metal, powder coated. Bevelled edges at the front and back allow slight cleaning. Mounting hole and raised base to secure lathe are pre-drilled. Length 495mm, width 215mm, height 150mm. The depicted lathe is not included in the offer.

NO 24 006



Dividing attachment TA 230
For lathe PD 230/E, MICRO miller PF 230 and FF 230

Facilitates the machining of gear teeth and non-concentric patterns. Supplied with two dividing discs (40 and 48 teeth), enabling standard divisions of 2, 3, 4, 5, 6, 8, 10, 12, 16, 20, 24, 40 and 48. The spindle of the attachment is identical to that of the lathe PD 230/E. The 3 (can be ordered separately under No 24 028, see below) and 4 jaw chuck (No 24 030, see page 49) may therefore be fitted to it as well (the chuck is an optional accessory). May be fitted to the lathe's cross slide or to the bed. Supplied in a wooden box with sliding lid. The 3 jaw chuck depicted here is not included in the offer.

NO 24 131

Self-centering 3 jaw chuck

Identical to the chuck of lathe PD 230/E. Radius 2 – 68mm (with reversing chucks). Body of steel. Suitable for lathe PD 230/E and the above described dividing attachment No 24 131.

NO 24 028

Mill/drill head PF 230
Converts the lathe PD 230/E into a complete machining centre.

Set includes column (35 x 400mm), mounting bracket and bolts. The mounting position on the PD 230/E is already milled. The lathe's top slide is replaced with the table (supplied) of 110 x 70mm, with 3 T-slots 12 x 6 x 6mm. The lathe now functions as a compound table, with X-Y travel being longitudinally and cross-wise respectively. The mill/drill head is identical to the MICRO miller FF 230 (see page 51). Three collets of sizes 6 – 8 and 10mm are included.

NO 24 104





A small, high accuracy machining system to mill, drill and bore.

MICRO miller FF 230

The headstock swivels through 360°, indicated on a scale.

Height is adjusted via a zero adjustable handwheel, also used as fine feed when milling (one revolution equals 1mm travel). The quill and headstock may be locked in position, essential when milling. The powerful motor effects drive via a poly-V belt, yielding high torques, especially at lower speeds. Collets of 6 – 8 and 10mm are included. The solid table is T-slotted to the MICROMOT standard of 12 x 6 x 5mm.

Other technical data:

220 – 240V. 140W. 50/60Hz. Spindle speeds of 280 – 550 – 870 – 1,200 – 1,500 and 2,200rpm. 30mm travel. Table size 270 x 80mm, column 35 x 400mm long. X-Y-travel is 170 x 65mm. Maximum height 180mm and depth 130mm. Overall height approx. 500mm. Weight approx. 17.0kg.

NO 24 108

The clamps (not included) are described on page 57.

Note:

For more lathe and milling accessories and bits and cutters, see pages 56 - 57.

Important!

For clean milling we recommend to clamp the quill as well as the headstock onto the column. With the FF 230 this is easily done with the clamp.

Compound table KT 230

As described above, but excluding headstock and column. 35mm bore. Fits the PF 230 and PF 210. Weight approx. 11kg.

NO 24 106

Five piece collet set for PF 230 and FF 230

Includes 1 each of 2.4 - 3.0 - 3.2 - 4.0 and 5.0mm, for milling cutters. Supplied in a wooden box with sliding lid.

NO 24 144

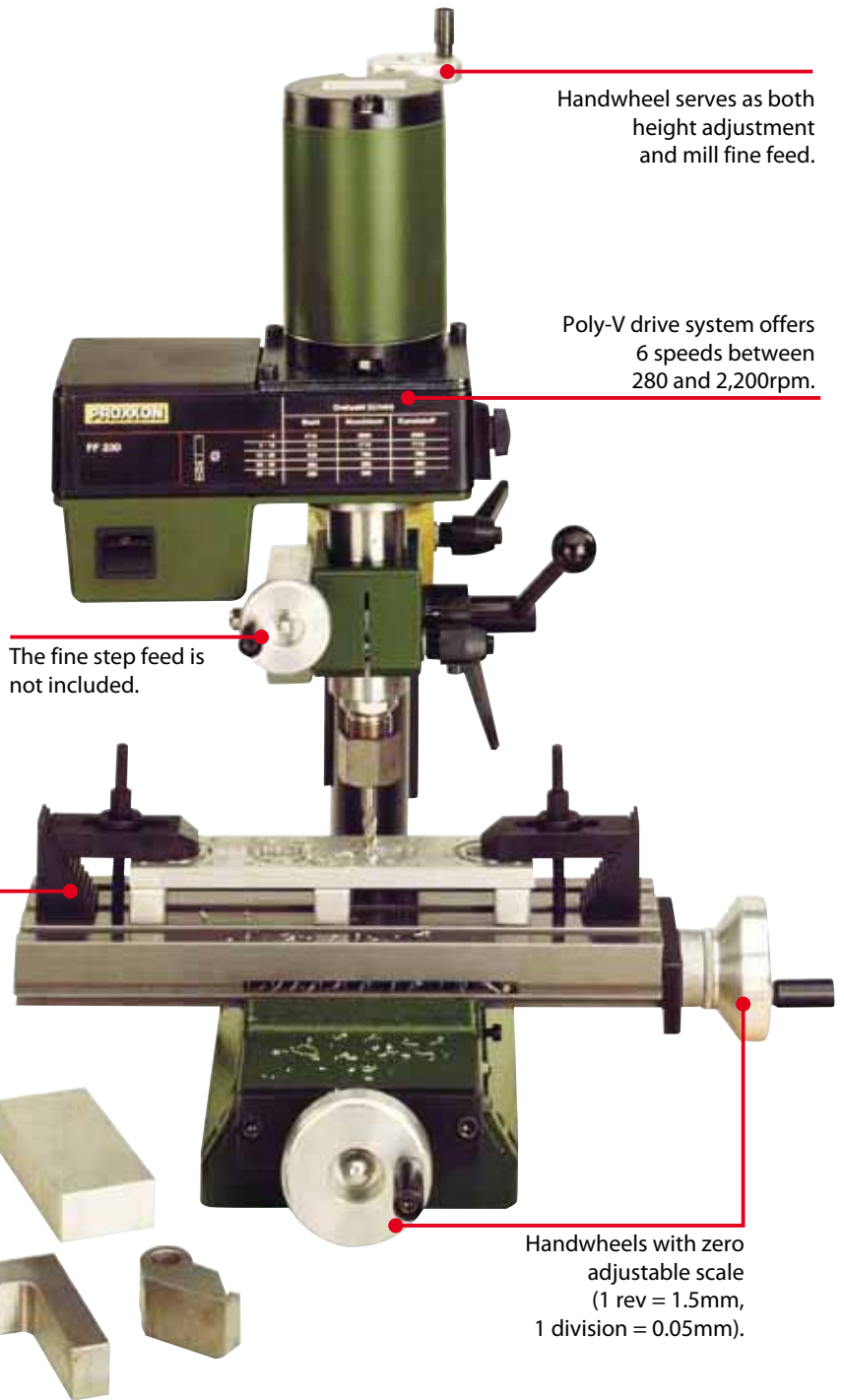

Handwheel serves as both height adjustment and mill fine feed.

Poly-V drive system offers 6 speeds between 280 and 2,200rpm.

The fine step feed is not included.

Handwheels with zero adjustable scale (1 rev = 1.5mm, 1 division = 0.05mm).

Fine feed for milling machine PF 230 and MICRO miller FF 230

Easily installed in a few seconds.

The feed may be used via either the height feed (vertical) or the fine feed in the tilted position. The graduated scale may be zero reset. One revolution is equivalent to 1.5mm spindle travel (1 division = 0.05mm).



NO 24 140

Note:
Accessories and insertion tools for
the PD 400 system,
see pages 54 - 57.



Complete with change gears to cut threads
(in 19 steps from 0.2 to 3.0mm).
Clearly positioned and easy to change.

Main switch with auto-start protection
and emergency off.

RÖHM precision feed
(Ø 100mm).

Powerful capacitor motor with 550W
output power.

Selector
for auto-feed.

Switch for clockwise, off and
counter-clockwise rotation.

Apron handwheel.

Quick-change tool post with
2 holders (with stop and height
adjustability).



**The Lathe PD 400 is the heart of a multifunctional and expandable system
and is unequalled in its class!**

Ideal for straight and cross cuts, taper turning, internal and external thread cutting, slotting, etc. Useable on materials such as steel, non-ferrous metals, aluminium and alloys. Negligible tolerances even under heavy loads. The wide range of accessories complements the lathe's functions. The bed is already equipped with a milled and tapped surface for securing mill/drill PF 400.

Technical data:

Distance between centres 400mm and cross slide travel 85mm, over the top slide is 116mm. Solid, ribbed bed is made from quality cast iron with ground and hardened ways. Oversized spindle with 2 adjustable taper bearings, MK3 taper and 20.5mm bore. Run-out, without chuck, 5/1,000mm. Includes the precision 3 jaw chuck, 100mm diameter. Six spindle speeds are provided via belt drive: stage 1: 80 – 330 – 1,400rpm and stage 2: 160 – 660 – 2,800rpm. Powerful, quiet motor

with 550W power output. Practical handwheels with zero adjustable graduated collar (2 parts). For cross slide and upper carriage: 1 division = 0.025mm. 1 rev. = 1.0mm. For tailstock and leading spindle: 1 division = 0.05mm. 1 rev. = 1.5mm. The activatable auto feed has speeds of 0.07 or 0.14mm/rev. An integrated gearbox, for LH and RH threads, with change gears provides 19 metric pitches: 0.2 - 0.25 - 0.3 - 0.35 - 0.4 - 0.45 - 0.5 - 0.6 - 0.7 - 0.75 - 0.8 - 0.9 - 1.0 - 1.25 - 1.5 - 1.75 - 2.0 - 2.5 - 3.0mm. Imperial threads of 10 - 48 TPI are also possible.

A rotating centre MK 2 and tailstock



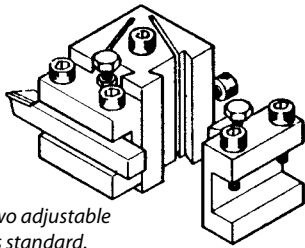

A tool holder with two adjustable inserts is included as standard.

Tool post

Including two holders. Provides quick tool changes with easy height adjustment.
NO 24 415

Individual quick-change holder

Fits the tool post of PD 400.
NO 24 416



4 jaw chuck with independent jaws

Used to mount irregularly and asymmetrically shaped objects. Each jaw is adjusted individually and centering is thus achieved manually. Hardened, reversible jaws. Chuck diameter 100mm.

NO 24 410

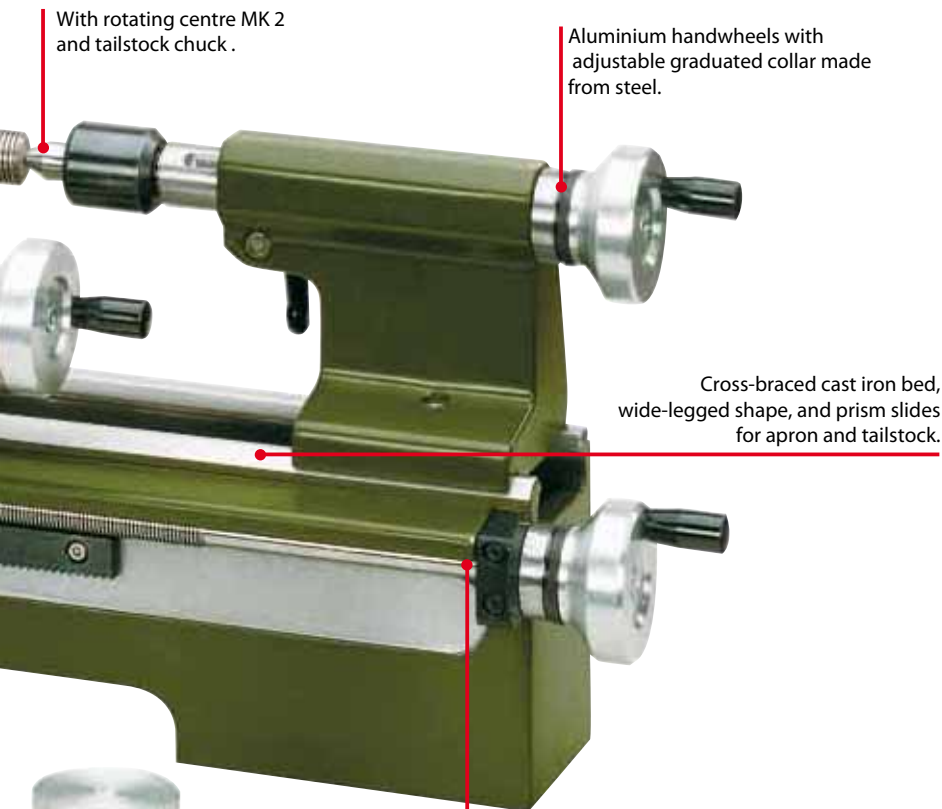

With rotating centre MK 2 and tailstock chuck.

Aluminium handwheels with adjustable graduated collar made from steel.

Cross-braced cast iron bed, wide-legged shape, and prism slides for apron and tailstock.



4 jaw chuck, self-centering

The jaws are not independently adjustable, i.e. they are self-centering. High accuracy. Chuck diameter 100mm.

NO 24 408



Protected lead screw with 12 x 1.5 Acme thread.

Note:

The lathe PD 400 is now also available as CNC version with recirculating ball spindles, step motors and user-friendly WINDOWS-compatible software. For more information, please visit our website at www.proxxon.com. Or request our special brochure!

chuck of 10mm capacity, B12 taper, are included. Lead screw with acme thread 12 x 1.5, top slide 52mm and adjustable to turn tapers, with graduations up to 45°.

Tailstock with MK 2. 24mm diameter and 40mm travel (with graduations).

Overall size approx. 900 x 400 x 300mm (L x W x H). Weight approx. 45kg. Uses cutting tools 10 x 10mm.



NO 24 400



Faceplate and clamps

Is fitted instead of the standard chuck. Ideal for clamping larger and asymmetrically shaped work pieces. Ø 125 mm. 2 continuous T-slots. With clamping jaws.

NO 24 412

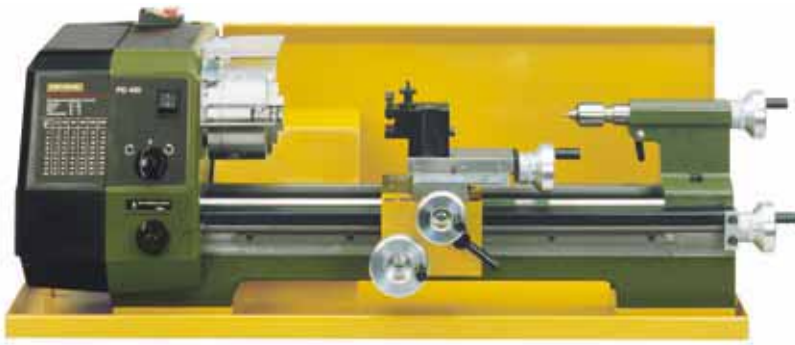

Splash guard and chip collecting tray for lathe PD 400

Made from 1.5mm steel plate, powder coated. A welded cover protects the motor. Mounting holes and raised base to secure the lathe are pre-drilled. Seeping through of coolant is impossible. Length 800 x width 270 x height 290mm.

NO 24 402



Fixed steady

Used on the PD 400 when turning long, slender work. Fitted directly to the bed-ways and is used when the tailstock support is inadequate. Maximum Ø 50mm.

NO 24 404



Travelling steady

Fitted to the carriage of the lathe. Indispensable when turning long, slender pieces. Maximum Ø 50mm.

NO 24 406



Collet set

For accurate use on round components. One each 2.0 – 3.0 – 4.0 – 5.0 – 6.0 – 8.0 – 10 – 12 and 14mm are included. Concentric accuracy better than 0.002mm, much better than a chuck. One soft collet for making a custom size yourself. The included collet attachment is mounted in the place of the headstock chuck. Supplied in a wooden box.

NO 24 419

Collets only

Mill/drill PF 400

Kit also includes the mounting flange and screws (the mounting surface on the PD 400 is already machined). Work surface of steel (150 x 110mm), with 3 milled T-slots for the standard T-nuts, is supplied. Two screws secure the work surface to the cross slide.

NO 24 304



Centre turning accessory for the PD 400

Ideal when turning with highest possible accuracy. Supplied with 2 dead centres (MK2 and MK3), drive/face plate with 30mm bore as well as reducing bushes 30/20mm and 30/15mm. A threaded drive pin screws into the headstock flange and the drive plate.

NO 24 414

Gear tooth chuck (10mm) with adapter

Industrial quality, however not as accurate as the collets. With 10mm adapter which fits into the 10mm collet. Includes the chuck key.



NO 24 110



**MICRO miller for precision work to 0.05mm accuracy!
Quiet, looking good and multifunctional.**

MICRO Miller FF 500

Drive: powerful, quiet condenser motor.

Poly-V belt drive for 6 spindle speeds between 180 and 2,500rpm.

Solid column with dovetail guides.

Clamping jaws, miller and work pieces are not included in the delivery.

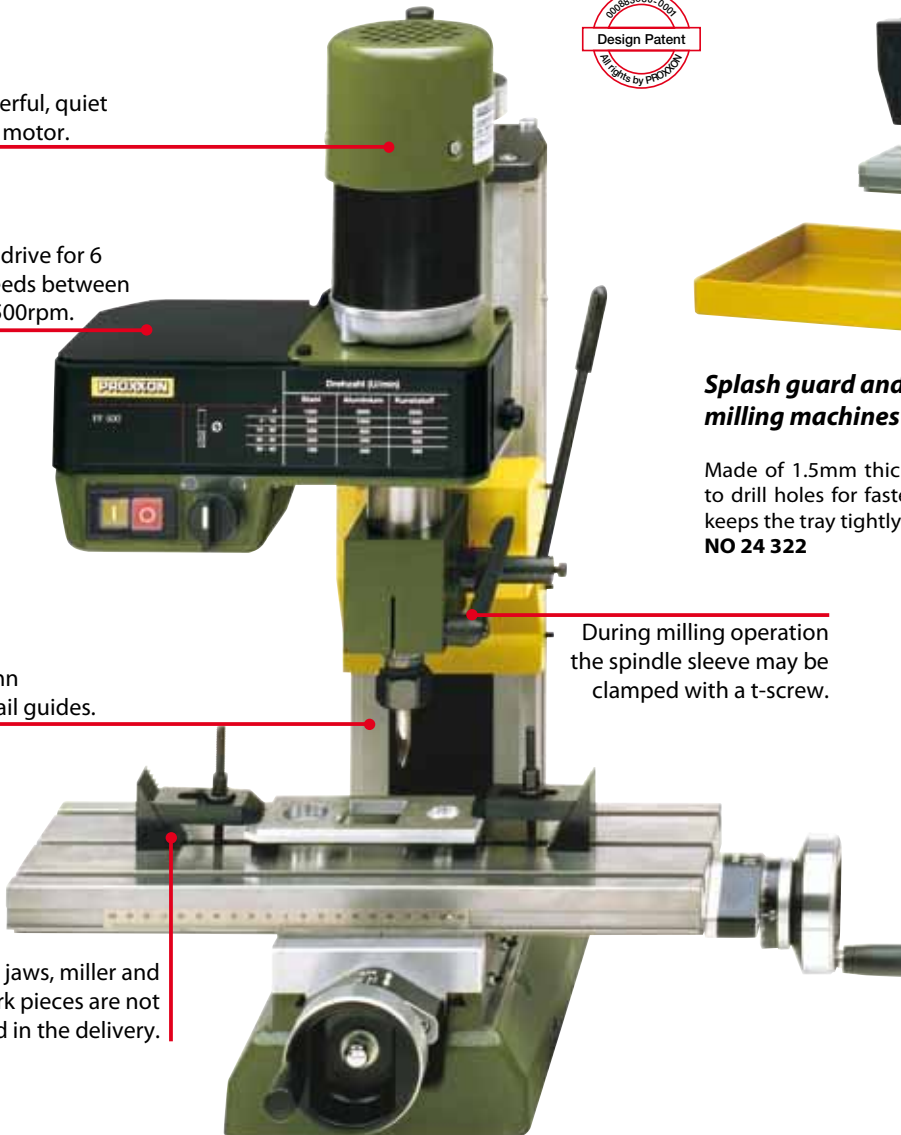

During milling operation the spindle sleeve may be clamped with a t-screw.

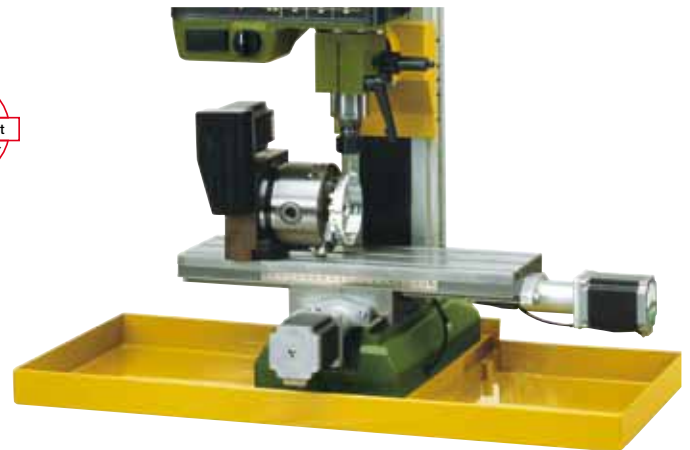

Splash guard and chip collecting tray for PROXXON milling machines

Made of 1.5mm thick sheet steel, powder-coated. Secure stand due to drill holes for fastening to a work surface (the use of steel sleeves keeps the tray tightly sealed). L 700mm, W 420mm, H 40mm.
NO 24 322

Note:

The Miller FF 500 is also available as "Ready for CNC" version: With recirculating ball spindles and powerful step motors on all 3 axes, and also as full CNC version with control unit and user-friendly WINDOWS®-compatible software. Including a dividing attachment as 4th axis for 3D processing. For more information, please visit our website at www.proxxon.com. Or request our special brochure!

A machining centre for milling, drilling and countersinking. With solid column of aluminium continuous casting.

Milling head can be pivoted to the left and right by 90° (with degree graduation). Preset rotational speed simply by moving the Poly V-belt. Sleeve feed (30mm) using drilling lever with scale ring (1 graduation line = 1mm).

Tool holder using 6 – 8 – 10 und 12mm collets (included). Extension height adjustment using hand wheel with scale ring (1 rev. = 2mm). Solid, plane-milled T-slot compound table in steel with three continuous T-slots for size 8 standard nuts.

Technical Data:

220 – 240V. 400W. 50/60Hz. Spindle speeds 180 – 350 – 550 – 800 – 1,300 – 2,500rpm. Throat (to spindle centre) 125mm. Sleeve stroke 30mm. Column 120 x 100 x 420mm. Table 400 x 125mm. Traverse range vertical (z-axis) 220mm, transverse (x-axis) 310mm, depth (y-axis) 100mm. Total height max. 780mm. Weight approx. 47kg.

NO 24 320

Collet set for PF 400 and FF 500 millers.

1 piece each for miller ø 2.4 – 3.0 – 3.2 – 4.0 and 5.0mm. In a wooden box.

NO 24 252



Fine feed for accurate adjustments

Quick and easy to install. The clutch system enables feed via either the drill handle or the handwheel.

The handwheel has 0.025 graduations and may be set to zero. 1 division = 0.05mm.

NO 24 254

Nearly all the components are supplied in sturdy wooden boxes.



Universal dividing table UT 400

Facilitates the manufacture of odd-shaped objects.

The table may be fixed horizontally or vertically. Drive takes place via the worm drive and in its 360° travel yields nearly all the divisions below 100. Supplied with 4 index plates: 27/42, 33/40, 34/39 and 36/38. Used to manufacture sprockets, gearboxes and drives, ratchets, cams, etc. The faceplate is not included. The taper is identical to the head spindle of the lathe. Supplied in wooden box with sliding lid.



NO 24 421

Tool holder for rotary tools.
For use on lathe machines.



Made of steel 30 x 10 x 65mm.

This holder allows mounting of our rotary tool LB/E or IB/E to the tool post of the lathes PD 230/E and PD 400 for grinding or polishing purposes. MICROMOT collar size Ø 20mm. Shaft 8 x 10mm for tool holders PD 230/E and PD 400.

NO 24 098

Die holder for round dies, threads M 3 to M 10



Sizes: M 3 – 4 – 5 – 6 – 8 – 10. The straight shaft fits the holder Ø 10mm when mounted in the tailstock of the PD 230/E or PD 400. The holder is held by hand while cutting the threads. Comes in a wooden box.

NO 24 082

Precision V-blocks

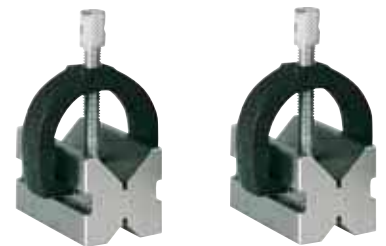

Used to clamp various work pieces.

Made from hardened steel, precision ground in pairs. Four different depths of prism incisions V, all at 90°. Size 50 x 30 x 30mm. The solid clamp and knurled knob ensure superb securing of the workpiece. Supplied in a wooden box with sliding lid.

NO 24 262

2 pieces

14-piece parallel supports set
Ground in pairs



For adjusting work on drilling machines, lathes and milling machines.

Made of high-alloy, hardened steel (58 - 62 HRC). Parallel accuracy 0.002mm. 2 each of 8 x 10, 15, 20, 25, 30, 35 and 40mm. Length 100mm. Packed in a wooden box.

NO 24 266

Radius cutting attachment



Usable on both the PD 230 and PD 400 systems, is mounted on the cross slide in place of the tool holder. Cuts convex and concave shapes to depth of 1.0mm in steel as well as in non-ferrous metals and plastics. Radii or 3/4" spheres of diameter up to max. 32mm are possible. Comes with one finishing cutter 8 x 8 x 80mm in a wooden box with sliding lid.

NO 24 061

Precision vise

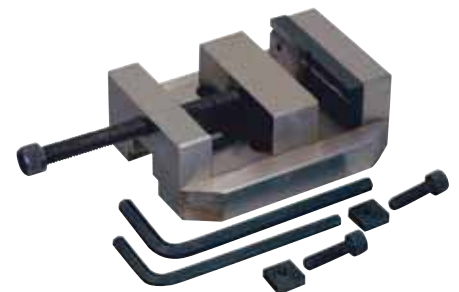

Milled in steel.

May be used on its side and back. Jaw width of 60mm, clamping capacity 42mm. Complete with securing bolts and packed in a wooden box with sliding lid.

NO 24 255

**Milling cutter set
(2 - 5mm)**

All cutters with 6mm shaft. Cutters of Ø 2 - 3 - 4 and 5mm. Double fluted according to DIN 327. Made of HSS. Supplied in wooden box with sliding lid.



NO 24 610

Milling cutter set (6 - 10mm)

4 cutters Ø 6 - 7 - 8 and 10mm. Four flute design according to DIN 844. Shafts 6.0 and 10.0mm respectively. Made of HSS. Supplied in wooden box with sliding lid.



NO 24 620

Three piece centre drill set

Made of HSS steel. DIN 333 (type A) 60°. Complete set centre drills with sizes of 2.0 - 2.5 and 3.15mm.



NO 24 630

Step clamp set, of milled steel

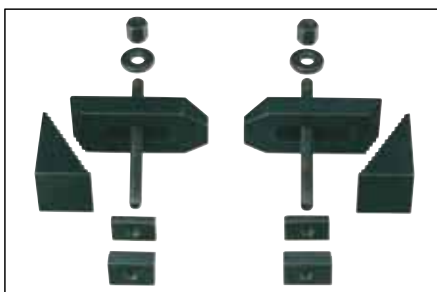

2 each step blocks, 2 clamps, 2 nuts and 2 T-slot nuts (B = 7mm, E = 12mm, D = 4mm, C = 7.2mm). For work pieces up to approx. 35mm thickness. May be used with PD 230/E, PF/FF 230, PD 400, PF/FF 400, FF 500, BFB 2000, faceplate 24 412 and KT 150. In wooden box with sliding lid. Description of „smaller“ version NO 24 256 on page 18.

NO 24 257

Cutting tools of high quality cobalt HSS steel, ground.

Five piece set

One each roughing out, parting, finishing cut, left and right cutter. Supplied in wooden box with sliding lid. 8 x 8 x 80mm (for PD 230/E).



NO 24 530
10 x 10 x 80mm (for PD 400)
NO 24 550

Three piece thread cutting set

One cutter for external thread (ground to 60°, metric) one for internal thread, one general cutting. Supplied in wooden box with sliding lid. 8 x 8 x 80mm (for PD 230/E)



NO 24 540
10 x 10 x 80mm (for PD 400)
NO 24 552

Parting tool holder and tool

Used in the PD 400 quick-change system. Used to part stock and cut slots. The 12 x 3 x 85mm HSS tool contains cobalt.



NO 24 417

Spare tool for parting tool holder

As described above.
NO 24 554

Cutter set with tungsten inserts for PD 230/E and PD 400



Three holders (90mm long)
① for roughing out;
② for longitudinal work;
③ for 90mm boring bar, holes from 12mm. Standard tungsten inserts, 55°, plated (commercially available version). Three additional inserts securing screw and key TX 8 are included.
NO 24 555 8 x 8mm (for PD 230/E)
NO 24 556 10 x 10mm (for PD 400)

Tungsten disposable tips

For the holders as described above.
NO 24 557 Ten piece set.

HSS boring tool set, 6 pieces



One each cutter for 60 degree (metric) and 55 degree (Whitworth) inside threads, 1.3mm - 2.65mm and 4mm. Shaft of Ø 6mm. Length 95mm. The cutters are held by a tool holder that mounts to the tool post of either the PD 230/E or PD 400. Comes in a wooden box.
NO 24 520

Edge finder set



Used for fast and accurate location of starting point of work pieces with respect to the machine spindle on milling machines. Size 6 x 6 x 50mm and 6 x 5 x 75mm. Neatly packed in a wooden box.

NO 24 434

Mill/drill system BFW 40/E, with controller for speeds of 900 - 6,000rpm.

The triple ball bearing armature provides direct drive (no gearing).

Die-cast aluminium head with spindle neck of 43mm (European standard). Large, easy to use switch with emergency function. Chart indicates optimum speeds for milling and drilling of various materials.

Other technical data:

Control unit with full wave electronics for 220 - 240V, 40VDC secondary voltage. Power consumption up to max. 250W.

Spindle speed infinitely variable between 900 and 6,000rpm. Complete with triple slit, hardened collets covering 2.35 - 3.0 - 3.2 - 4.0 - 5.0 and 6.0mm. as well as 2 spanners.



Note:
The motor operates at 40V, supplied from the power pack/controller. At this level, the control characteristics are ideal and yield high torque, even at lower speeds.

(The compound table, drill stand and step clamps are not included.)

NO 20 165

Die-cast aluminium compound table KT 150

With precision milled dovetail slides, thus also suitable for metal work.

For routing, milling, slotting of steel, non-ferrous metal, plastic and wood. Each slide provided with locking screws. Dovetail fittings/gib strips adjustable to eliminate play. Feed adjustments by means of 2 handwheels with adjustable, graduated dials (one revolution =

2mm, one graduation = 0.05mm). Machined table, 3 T-slots for fastening machine vices and clamping kits. Fence supplied with pre-drilled positioning holes, including 45°, fastening screws and clamp used for routing.

Table 200 x 200mm. Maximum travel 150 x 150mm. Overall height 75mm. Weight 4.9kg. The clamp shoes right in the illustration are not included.



NO 20 150



BFB 2000, see page 59.



High strength precision die-cast aluminium,
with precision milled dovetail slides.

Mill/drill unit BFB 2000

For standard drills with 43mm spindle neck.

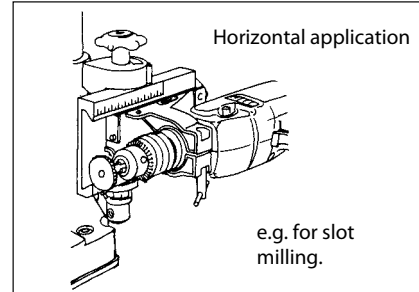
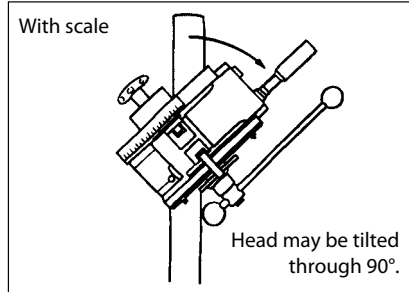
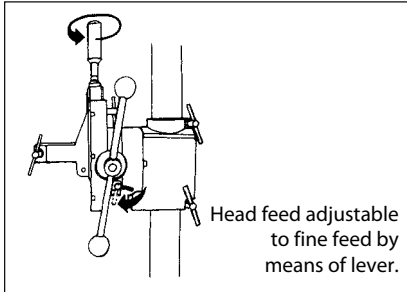

Head with precision milled dovetail slide and may be tilted through 90° to give all-round versatility: diagonal drilling, versatile without need of special milling bits, milling diagonal slots. Fine feed selectable, allowing fine head feed for milling. With dial and depth scale. Geared rack and pinion feed for effortless drilling. 45mm diameter drill column, 500mm long. Approx. 140mm throat (column outside to tool centre). 65mm stroke. Machined, solid base plate approx. 200 x 200mm. All drills with standard 43mm spindle collars may be utilised directly: BOSCH, AEG, FEIN, METABO, KRESS, BLACK & DECKER, SKIL. Weight approx. 6.5kg.
NO 20 000

HSS milling cutter set (2 - 5mm) Ideal for mill/drill system BFW 40/E



HSS, all with 6mm cylindrical shaft. Consists of cutters of 2 - 3 - 4 and 5mm diameter. Double fluted, according to DIN 327. Made of HSS. Supplied in wooden box with sliding lid.
NO 24 610

Stepped clamps, of milled steel. Compatible with compound table KT 150

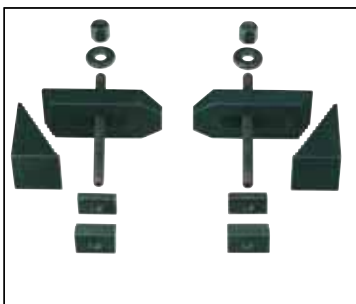

2 each step blocks, 2 clamps, 2 nuts and 2 T-slot nuts. For work pieces up to approx. 35 mm thickness. Compatible with compound table KT 150 and millers FF 400/PF 400 and FF 500. Neatly packed in wooden box with sliding lid.

NO 24 257

For more accessories, see page 57!

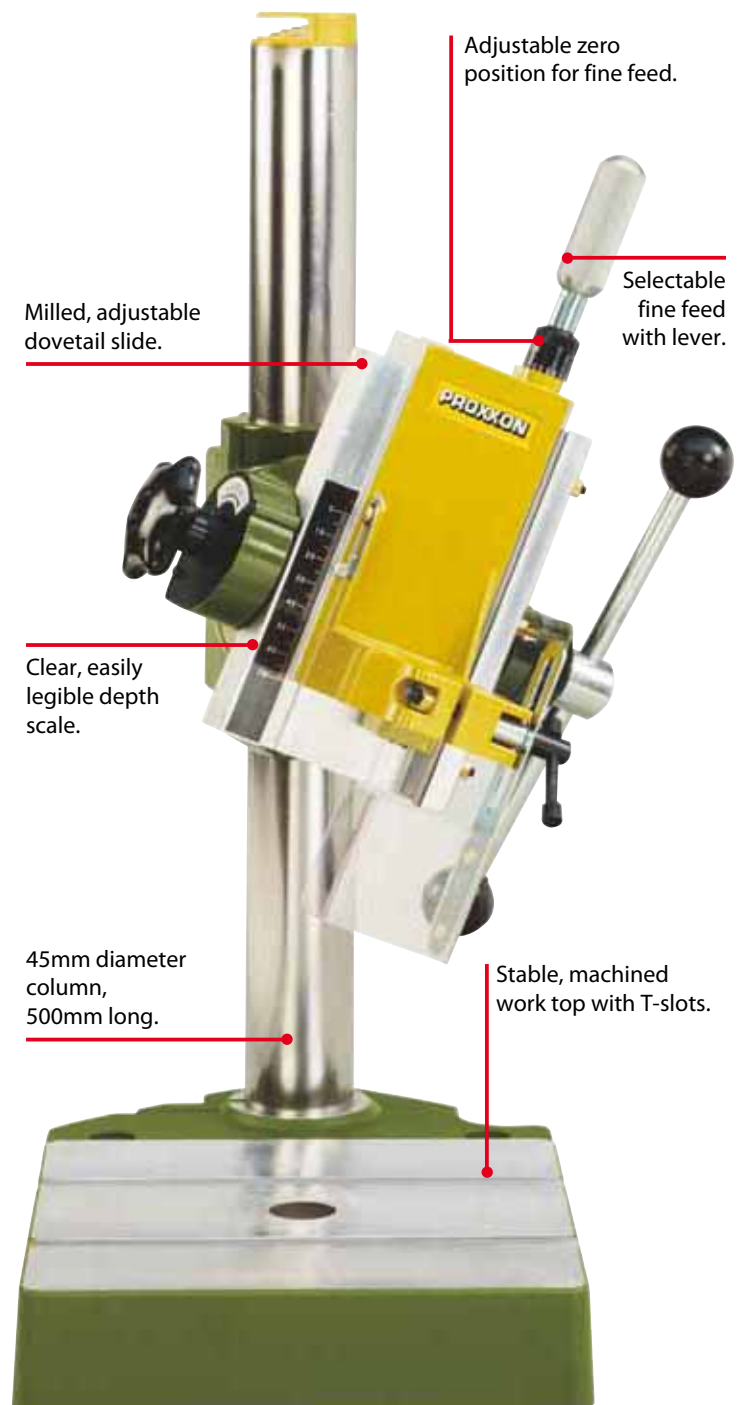



PROXXON GmbH
 Industriepark Region Trier
 Dieselstraße 3 - 7
 D-54343 Föhren

Tel.: +49 (0) 65 02 – 93 17 – 0 • Fax: +49 (0) 65 02 – 93 17 – 200
 E-mail: export@proxxon.com • www.proxxon.com



We reserve the right to technical modifications as a result of improvements.
 Errors and omissions excepted.